

DNM INDUSTRY CO.,LTD.

☎ +886-4-22706191
☎ +886-4-22708734
✉ dnm@dnmshock.com
🌐 dnmshock.com

DNM CHINA RUHON SUSPENSION CO.,LTD

☎ +86-755-29882495
☎ +86-755-29882269
✉ dnmsbox@163.com

DNM ITALY-DH+ CONTROL SYSTEM Via Don Minzoni 88A

☎ +39-032-1885301
☎ +39-032-1885560
✉ giorgio@dnmsuspension.it
🌐 www.dnmsuspension.it/dnmweb/
📍 28043 Bellinzago Novarese(NO),Italy

GERMANY

Vector Bike

☎ +49-157-56507678
☎ +39-032-1885560
✉ info@vectorebike.com
🌐 www.vectorebike.com



USA

CyclingDeal

☎ +1-909-397-4025
✉ joey@cyclinglealusa.com
🌐 www.cyclinglealusa.com

AUSTRALIA

CyclingDeal

☎ +61-3-97939188
✉ sales@cyclingleal.com.au
🌐 www.cyclingleal.com.au

FORK OWNER'S MANUAL 使用説明書

USD-8A / 8SA

USD-8 / 8S / 8C

USD-24 / 24S

USD-8-FAT

USD-6

USD-6-FAT



dnmshock.com

DNM Suspension

Thank you for choosing DNM bike Fork. Fork is already installed and can be directly installed on your bike. Please install reflector before hit the road. (*Reflector is not mounted on this model).

Diagram Consumer Safety /  : warning  : Attention

Consumer Safety

Cycling is a dangerous sport. Rider must control the bike very cautiously at all times to prevent possible injuries. Clean the fork before each ride. Thoroughly examine the fork at bright place to ensure no damages on the fork. After delivery or fall, check especially for: Crown, spindle tube, beam tube, leg, hook claw, brake joint and most forced parts (e.g. joint sleeve, holes and contacts). Do not ride the bike if fork is bended, oil (air) leakage, breaks, cracks, metal crash sound or other sound, or any missing original parts. Please consult with our distributors or DNM customer service if you have any questions towards the function and integrity of DNM bike fork.

※Bike fork is NOT used for any artistic cycling or dangerous actions!

※Do NOT perform any artistic cycling or dangerous actions after compression locked up!

Harmful Actions to Bike Fork life spam

Situations that will decrease the bike fork' s life spam:

(1)Overused (2)Ride on bumpy road (3) Overweight user
(4)Improper installation /maintenance (5) Much harsher environment (6)Fork damaged due to car crash, bike jump or other situation. Bike fork life spam is affected by the above situations.

High speed downhill, floral cycling or racing

High speed downhill, floral cycling and racing are all voluntary high risk bike riding method which can cause severe accidents. Those riding method can bring extreme pressure to shock absorber, bike fork and other parts, which cause these parts easily worn out. Before attending those high risk activities, please ask professional technicians to check/ replace consumable parts in advance.

The Run-In Period

New bike fork needs 20hrs of run-in period. Adjust the bike fork after run-in period. The bike fork can run more smoothly after run-in period.

Install the Crown

Spindle tube and beam tube are installed in the factory, designed as permanent mount parts. If disassemble the spindle tube or beam tube, it will damage the crown permanently and cannot be fixed. Do not install bike tooth on un-toothed beam tube, it will weaken the beam tube and cause danger to user. Replace the crown in whole set.

Installation Description

Make sure the bike fork are mount with correct beam tube; cut the tube before mounting to your bike. If you are not familiar with the process or have no proper tools to cut the tube to the right length, please find a dealer with qualified technician to do this. Confirm the tube length before and after cutting. Overcut tubes are not guaranteed by maintenance certificate.

Install brake wiring

If brake wiring is not properly wired and firmly connected to bike fork, the brake wiring will touch the tire and cause possible injuries or death. Fix the brake wiring on the wire clip of shock absorber. Make sure brake wiring is not twisted and will not touch the tire during the stroke.

Repair & Maintenance

Bike fork must be regularly maintained, cleaned, examined based on the difficulty of the ride and the worn degree of bike fork. Please do regular maintenance / repair to make sure the fork' s best performance. Clean the shaft tube and parts after each ride to extend their life spam.

Guarantee

Bike fork is precise parts. If damaged/broken due to improper use or disassemble, will not be covered by the guarantee terms.

The To-Do List Before Each Ride

1. Well adjust all quick release parts.
2. Fasten all screws by proper torque based on distributor' s suggestion.
3. Clean the shaft and fork and check the fork must have no scratches.
4. Ensure brake wiring are wired well and adjust the brake.
5. Adjust & fasten bowl set by distributor' s suggestion.

! Define your ride type

Trek Bike Ride (TK): Similar to XC ride but not as tough. TK ride includes riding at slower speed on flatter road without obstacles like rocks, branches or pits. Cross Country Ride (XC): It includes riding on the hill roads with more obstacles like rocks, branches and pits. XC ride does not include jump or fall from any heights. XC bike fork can only be used with professionally designed bike frame and tires. XC fork and format brake system are compatible. All Mountain Ride (AM): Tougher ride on harsh environments with larger obstacles. AM Ride does not include jump or fall from any heights. AM bike fork should only be used with disk brakes and bike frame, tires and other parts specially designed for AM ride.

! "Downhill", "Bumpy" or "Racing"

High speed cycling or downhill bike racing are considered voluntary high risk activities. Downhill ride and floral cycling both can cause severe accidents. The speed of biking downhill sometimes can be even faster than motorcycle speed, and cause similar damage and hazard. Please prepare proper protective equipments, e.g. helmet covering the whole head, protective item covering whole arms, fingers and feet. Ask professional technician to check your bike and maintain your bike thoroughly and more often before each ride (downhill, bumpy or racing).

! Install bike fork — Single shoulder base fork

1. Remove the old bike fork from the bike frame.
2. Measure and cut direction turning tube (according to the direction turning tube of the old bike fork) to match with the front tube of bike frame.
3. Remove the base seal of front tube, then install it on the direction turning tube of bike fork, until it is fixed on top of the shoulder base according to the distributor's instructions.
4. Clean and lubricate the front bowl bearing and base seal according to distributor's instructions.
5. Install lower bearing on the fork base seal according to distributor's instructions If applicable.
6. Insert direction turning tube into the bowl tube.
7. Install upper bearing, vertical tube bushing and vertical tube.
8. Install vertical tube cover and screws, fasten the screws base on instructions.
9. Install handle, fasten vertical tube screws and fasten unit according to vertical tube supplier's instruction.
10. Install and adjust the brakes according to brake supplier's instructions.
11. Position the quick release parts inside the hook claw holes, fasten it as instructed to ensure enough screws. Note: Standard hook claw fork is equipped with two time tire shield hook claw to keep the tire inside the bike fork even when quick release parts are loosened.
12. Install brake wiring as instructed by the supplier.

***DNM inverted front fork series products will be inconsistencies in the length of the left and right legs when it is not installed with the axle hub. This is completely normal and not considered a faulty product ***

! Install brake wiring

It can cause severe injury or death if the front brake wire is not properly wired and firmly connected to the bike fork. The bike fork includes a small black disk brake wire guider, which can be connected to the fork and used to assist wiring on the disk brake pliers. The best method is to connect the brake wire through outside of the left leg of the fork. Make sure the brake wire is not squeezed or touch the tire in the stroke of bike fork.

Initial setting descending measure (suspension compressed amount caused by rider's weight at natural riding position). You need 1 roll meter, bind, 1 pencil, 1 piece of paper and one assistant.

1. Tie a bind on the fork leg, push the bind to the bottom until it reaches the top of dust proof ring.
2. Ask the rider to ride on the bike at gravity centered position, feet on the pedal. Let the rider get off the bike and let fork return to its original position.
3. The preload adjust knob is on the spring fork. Turn the knob clockwise to increase spring preload and reduce descending stroke, turn the knob counter-clockwise to decrease spring preload and increase descending stroke.
4. Replace new bike parts if descending stroke is still not correct after adjusting preload or pressure.

Suggested repair interval of All DNM Suspension

Under normal use	
Short time/ Occasional ride	Long time/ often ride
Clean outer tube of bike fork every six months, Replace fork parts (e.g. suspension hydraulic O-ring, springs) at authorized DNM repair shop every two years.	Clean outer tube of bike fork every six months, Replace fork parts (e.g. hydraulic oil, O-ring, Spring) at authorized DNM repair shop every year.
Under harsh environment	
Short time/ Occasional ride	Long time/ often ride
Clean outer tube of bike fork every six months, Replace fork parts (e.g. hydraulic oil, O-ring, Spring) at authorized DNM repair shop every year.	Clean outer tube of bike fork every six months, Replace fork parts (e.g. hydraulic oil, O-ring, Spring) at authorized DNM repair shop every 10 months.

DNM Bike Fork USD-8A / 8SA Description

Diagram Consumer Safety /  : warning  : Attention

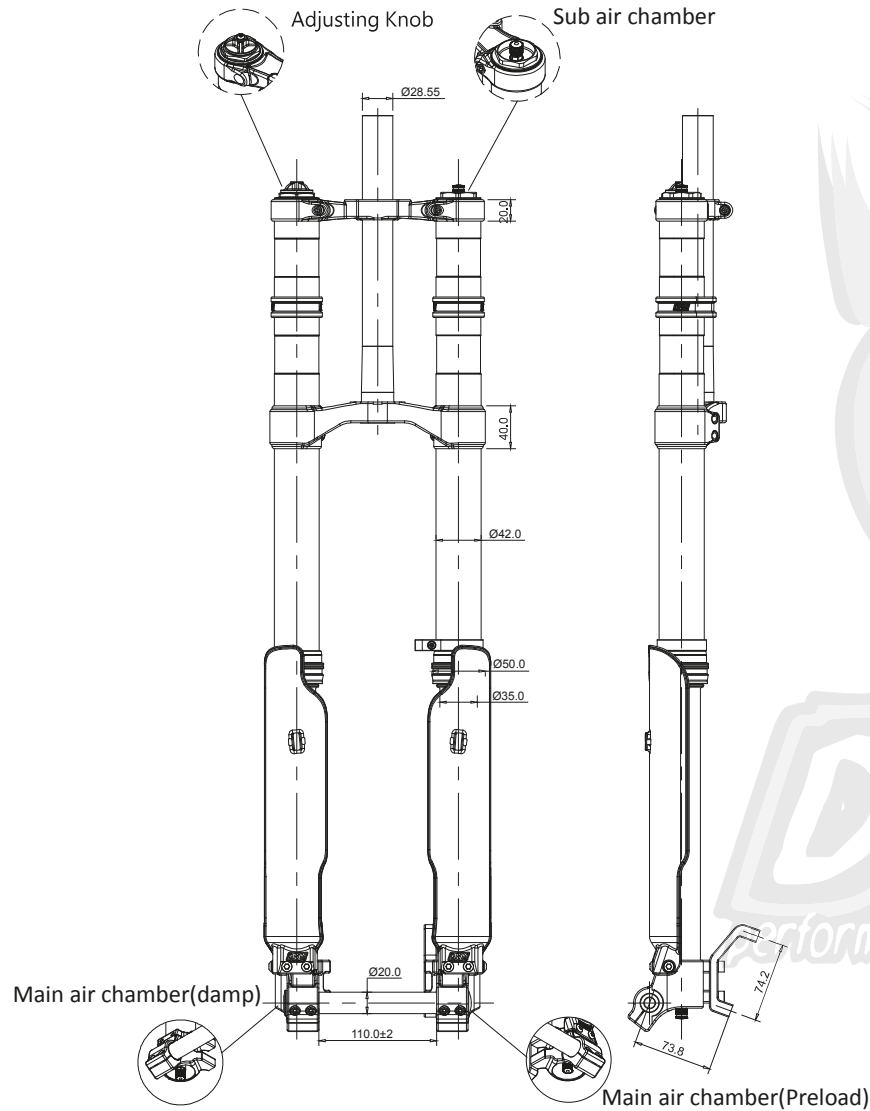

 **Adjusting knob**
 Turn + direction to increase damp (slow)
 Turn - direction to decrease damp (fast)

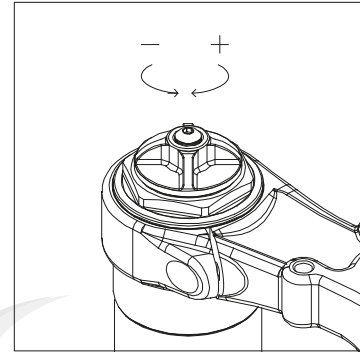

 **Sub air chamber**
 Please refer to form below of Suggested Pressure

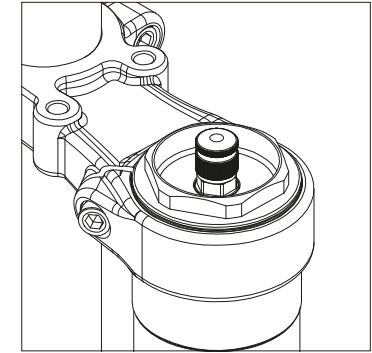

 **Main air chamber(damp)**
 Please refer to form below of Suggested Pressure

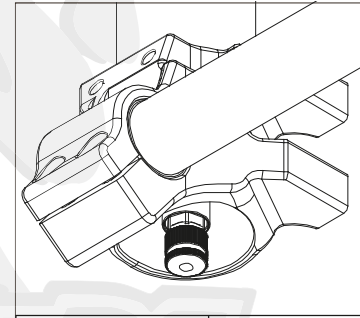

Suggested Pressure 100~150 PSI

 **Main air chamber(Preload)**
 Please refer to form below of Suggested Pressure

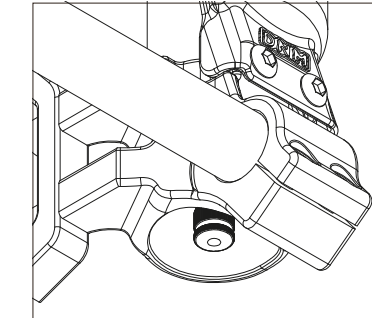

Suggested Pressure	
Main air chamber 80~150 PSI	Sub air chamber 45~120 PSI
Suggested Ratio	
80	45~60
100	65~80
120	85~100
150	105~120

©Please follow the recommended value, air pressure can be adjusted by user riding conditions, do not exceed the recommended values above, Otherwise it will lead to shorten the travel or total length, function loss and other consequences.

DNM 避震前叉

感謝您選擇購買本公司避震前叉。前叉已全組裝好，可直接安裝至您的自行車上，它配有 $\psi 28.6\text{mm}$ 束管、及碟煞(Post mount)接孔。路面行駛時必需安裝反光片，目前這支前叉沒有包括反光片。

圖示說明 /



: 警告



: 注意

! 消費者安全訊息

騎乘自行車是項具有危險性的運動，騎乘者須隨時掌控自行車，以減少傷亡的可能。每次騎乘之前，應清潔前叉，於光線充足之處細心檢查。以確保之前騎乘時無對避震器造成任何的損壞。運送或摔倒後需特別注意肩蓋、內管、外管、腳管、鉤爪、煞車橋接處和「受大力部位」(例如接縫、孔和同零件接觸點...等。)

若前叉出現任何彎曲、漏油(氣)、破損、裂痕、金屬碰撞或不熟悉之響聲，或丟失任何原裝零件，切勿騎乘。如您對避震前叉的功能，完整性或情況有任何問題，請於經銷商或DNM客服詢問。

*** 此叉又嚴禁使用在任何花式跳躍及其他危險動作!**

*** 壓縮鎖死後嚴禁做任何跳躍動作；及任何危險動作!**

! 避震器前叉使用壽命減少

以下情況會減少避震器前叉的使用壽命 (1) 超過一般使用者使用量 (2) 比一般不平路面騎車 (3) 您的體重超過一般使用者 (4) 安裝保養不當 (5) 比一般前叉接受更多惡劣環境 (6) 因撞車、飛躍或其他情況損壞前叉避震器。以上因素越多，越減少前叉的使用壽命。但無法說明壽命會減少多少。

! 高速下坡、花式或競賽

高速下坡、花式騎乘或競賽是自願冒高風險的騎乘方式，可致嚴重意外，以上騎乘方式會對於避震器帶來極度的壓力，零件受到極度的壓力，易產生嚴重的磨耗，避震器的壽命會因其磨耗而縮短。

如欲參加以上活動，需經由專業技師仔細檢查檢驗更替磨耗(損)零件，以確保避震器在活動中作用正常。

! 磨合期

新的前叉約需20小時的磨合期，在於磨合期之後，前叉的做動會較為順暢，磨合期之後可能需重新調整前叉，以達到最好的調整。

! 壓配肩蓋

束管和軸管是在原廠壓配完成，設計為已永不拆除。如把束管或軸管壓出，將會永久破壞肩蓋而無法修理，也是不安全而無法繼續使用。不要嘗試於無牙的束管上車牙，車牙會導致束管強度變弱，而於使用上造成危險。如欲更換肩蓋部分應整組進行更換，單獨拆卸更換將導致危險，也不應這樣做。

! 安裝說明

先確定前叉已經安裝上正確的束管，束管需經裁切才能正確的安裝到您的自行車上，如您對這個程序不是很熟悉，或者您沒有適當的工具進行剪裁長度，我們建議您找一家具有合格證書技師的經銷商去完成安裝工作，剪裁長度需確認長度再於剪裁，保修證明中並不包括修剪過短的前叉。

! 安裝煞車管線

若未把煞車線做適當的排線並牢固的連接到前叉，導致煞車線碰到輪胎，可能造成嚴重傷害或死亡。故請將煞車管線固定於避震器的壓線夾上，確定煞車線沒有擠壓變形，且於避震器的行程範圍中，煞車管線不會碰撞到輪胎。

! 維修保養

您的前叉必須定期保養、清潔、檢查，這是根據前叉騎乘的惡劣程度，為確保前叉的最佳性能，我們建議您定期維修保養，並於每次騎乘後，清潔軸管及元件密封處，以延長使用壽命。

! 保固需知

本公司產品之避震系統，屬精密元件。如產品由於不當使用、拆解而造成損壞或故障，將不在保固範圍內。

! 您應該在每次騎程之前

1. 確定快拆部件已經調整穩當及穩固。
2. 根據零件商的建議，所有螺絲已根據適合的扭距建議緊固。
3. 把軸管及清潔乾淨，並檢查前叉有無明顯破損。
4. 確定煞車管線已按規格排線妥當，並檢查煞車調整正常。
5. 檢查頭碗組是否已調整妥當，如有鬆動，根據廠商指示栓緊。

! 鑑別騎乘風格

跋涉式 (TK): 跋涉式類似於越野騎乘, 但是沒有越野式凶悍。跋涉式包括較慢騎乘, 通常在較平緩路面, 沒有好像石頭、樹枝及凹坑之類的障礙物。

越野式 (XC): 它涉及丘陵小徑的騎乘。途中會遇到石頭, 樹枝和坑坑洼窪的路面會比較多。越野騎乘不包括任何高度的跳動或下墜。越野前叉只能與專業設計的車架和輪胎一起使用。越野前叉與格式的剎車系統都適用。

全山地 (AM): 較凶悍的越野騎乘方式。涉及較大的障礙物和惡劣的環境地形。全山地的騎乘不包括任何高度的跳動和下墜, 這些前叉只應與盤式剎車以及特別為這種騎乘風格的車架、車輪和其它零配件。

! “下坡”、“顛簸”或“競賽”的騎乘

高速或競賽式下坡騎乘需自願承擔騎乘風險, 下坡騎乘或花式騎乘均可以導致嚴重意外事故。快速“下坡”可以達到比摩托車更快的車速並有類似危害和風險, 請配備適當的防護設備, 包括遮蔽整個頭部的頭盔和遮蔽全部手臂、手指及腳部的防護設備。每次騎乘前需給專業機械師檢查自行車確保自行車處在最佳的使用狀態, 對涉及下坡和顛簸的自行車進行全面徹底的保養比那些沒有此類活動的自行車更為重要。

! 安裝前叉—單肩座前叉

1. 拆下車架上的舊前叉。
2. 測量和切割轉向管, 以配合車架頭管, 您可以用舊前叉轉向管作為切割參照。
3. 根據頭碗廠商指示, 拆除頭管上的頭管座圈, 然後把他安裝到前叉轉向管上, 直到座圈固定在肩座頂部為止。
4. 根據頭碗廠商指示, 清潔和潤滑頭碗軸承和座圈。
5. 如果適用, 根據頭碗廠商指示, 把下部軸承安裝在前叉座圈上。
6. 把轉向管插入頭管內。
7. 安裝上部軸承, 立管襯墊和立管。
8. 安裝立管蓋和螺絲。根據頭碗廠商指示擰緊螺絲。
9. 安裝手柄桿, 並按照立管廠商規格來擰緊立管加固螺絲或立管加緊繫統。
10. 按照剎車廠商指示安裝剎車並進行調整。
11. 快拆組件在適當定位於勾爪沉孔內之後, 必須按照廠商規格來擰緊, 確保有足夠螺絲來配合。注意: 帶標準的勾爪前叉配備二次輪擋勾爪, 以防在快拆組件鬆開時, 車輪仍然可以留在前叉內。
12. 按照廠商指示安裝剎車線。

DNM前叉倒插系列產品在未安裝花鼓軸心時, 會有左右兩邊腳管

! 安裝剎車線

未能把前剎車線適當排線和牢固連接到前叉可能會導致嚴重傷害或者死亡。您的前叉包括一個小型的黑色盤式剎車線導向器。它可以連接到前叉上, 用以輔助線纜排布至盤式剎車製動鉗。我們發現最佳的方法是剎車線沿著前叉左腳管外側連接。請確定剎車線在前叉的行程範圍內不被夾擠也不會碰到輪胎。

初始設定

下走行程測量 (在自然騎乘姿勢下, 由於體重造成的避震壓縮量) 測量下走行程時您需要一把捲尺、束線帶、一支鉛筆、一張紙和一位助手。

1. 在前叉腳管上捆一條束線帶, 並把束線帶向下推至防塵圈的頂部。
2. 請騎乘者坐在自行車上面。務必要採取正確的騎乘位置 (重心位置居中), 並把腳搭在腳踏, 讓騎乘者從自行車上下來並使前叉返回全部伸展位置。
3. 在帶有預載調節器的彈簧前叉上。順時針轉動旋鈕會增加彈簧預載量和減少下走行程; 逆時針旋轉會減少彈簧預載量和增加下走行程。
4. 如果調整預載或氣壓未能提供正確的下走行程, 您可能需要新的騎乘配件。

所有DNM避震前叉的建議維修時間間隔

正常情況下	
短時間偶然騎乘	長時間頻繁騎乘
24 DNM建議廣大使用本公司避震前叉, 每半年把前叉外管清理乾淨, 每兩年對前叉內部零件進行適當的更換, 如需對前叉內部零件更換 (如減震液壓油、O型橡膠圈、彈簧等) 請到授權的DNM維修部進行更換。	25 每半年把前叉外管清理乾淨, 每一年對前叉內部零件進行適當更換, 如需對前叉內部零件更換 (如減震液壓油、O型橡膠圈、彈簧等) 請到授權的DNM維修部進行更換。
惡劣環境下	
短時間偶然騎乘	長時間頻繁騎乘
每半年把前叉外管清理乾淨, 每一年對前叉內部零件進行適當更換, 如需對前叉內部零件更換 (如減震液壓油、O型橡膠圈、彈簧等) 請到授權的DNM維修部進行更換。	每半年把前叉外管清理乾淨, 每10個月對前叉內部零件進行適當更換, 如需對前叉內部零件更換 (如減震液壓油、O型橡膠圈、彈簧等) 請到授權的DNM維修部進行更換。

DNM 避震前叉 USD-8A / 8SA 使用說明

圖示說明 /

! : 警告

! : 注意

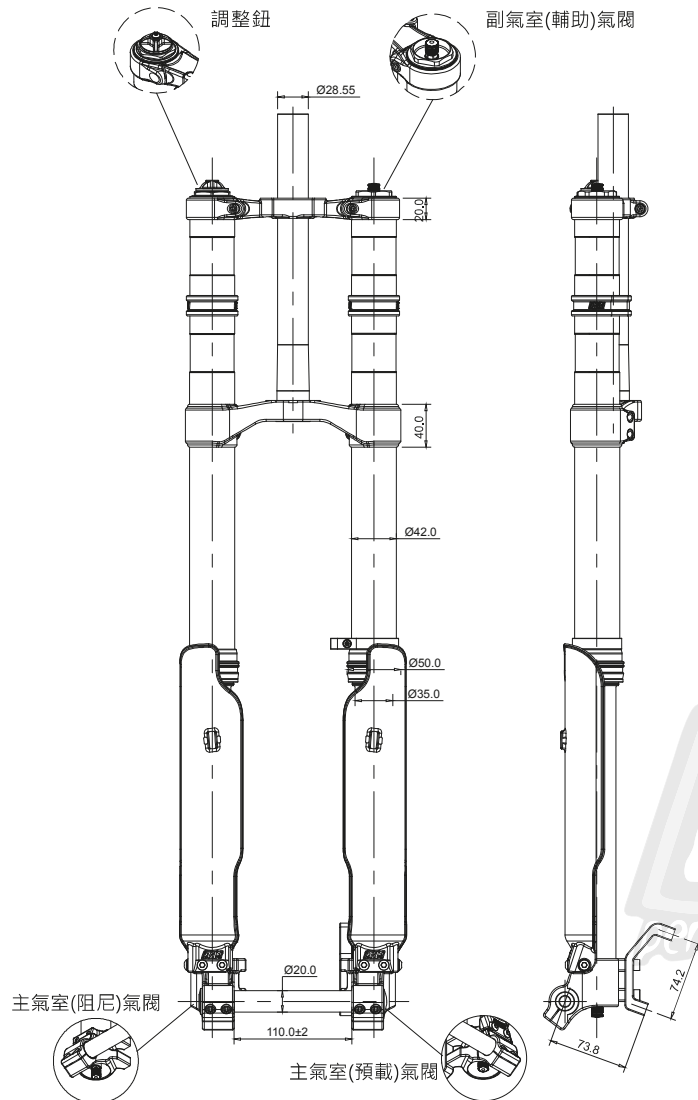

! 調整鈕

+ 方向旋轉 · 阻尼增加(慢)
- 方向旋轉 · 阻尼減少(快)

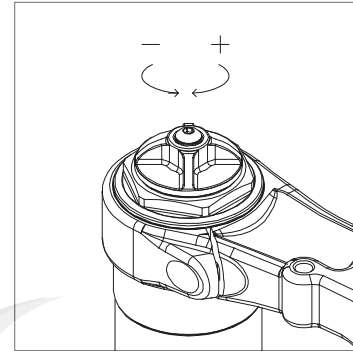

! 主氣室(阻尼)

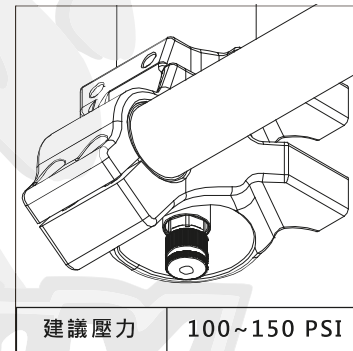

! 副氣室(輔助)

氣壓值為45~120 PSI
參考下表建議值

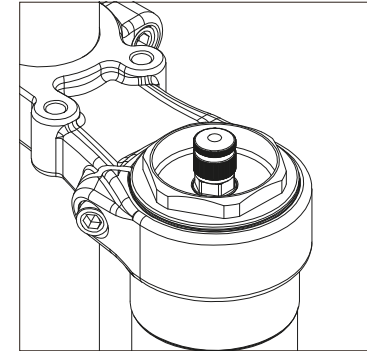

! 主氣室(預載)

氣壓值為80~150 PSI
參考下表建議值

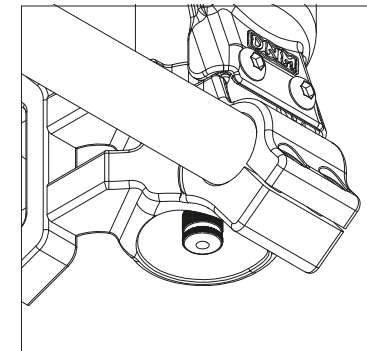

建議值	
主氣室(預載) 80~150 PSI	副氣室(輔助) 45~120 PSI
氣壓值 (PSI)	
80	45~60
100	65~80
120	85~100
150	105~120

◎ 依照建議值設定，主副氣室可由使用者騎乘狀況做調整，切勿超過上述之建議值，否則會導致行程及總長縮短、功能喪失等後果。